



## Specification of Digital MEMS Microphone

RoHS Compliance & Halogen Free

**YG Model:** SD3526B261-YY02

**Customer:**

**Customer Model :**

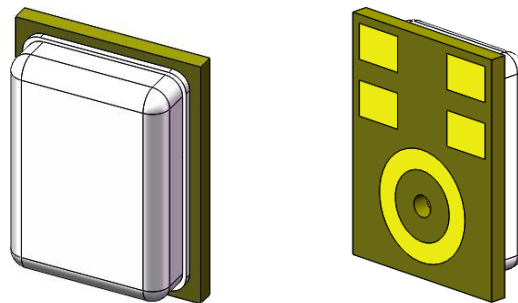

### YG

Designed by: Matthew Lee

Checked by: Echo Qiu

Approved by: Jack Liu

### Customer Approval

Approval by: \_\_\_\_\_

深圳市莺歌声学技术有限公司  
Shenzhen Yingge Acoustics Technology Co., Ltd.



Address: No.3018 Shennan Middle Road, Futian District,  
Shenzhen, Guangdong, P.R.C.

Tel: +86 755-83227251 13509631258 Mr.sun

Fax: +86 755-83012196

E-Mail: [yq@yinglear.com](mailto:yq@yinglear.com) [mic-acts@163.com](mailto:mic-acts@163.com)

QQ:1755836851 P.C.:518000

Website:<https://www.yinglear.com>



## Contents

1. Introduction	3
2. Electrical Characteristics	3
3. Timing Characteristics	5
4. Frequency Response Curve	5
5. Test Setup	6
6. Measurement Circuit	6
7. Mechanical Characteristics	7
7.1. Weight	7
7.2. Appearance Drawing	7
8. Application	8
8.1. Pickup Tool Pick Location & PCB Solder Pad Layout	8
8.2. Recommended Reflow Process Condition	8
8.3. Storage Condition	8
9. Packing	9
9.1. Tape & Reel Specification	9
9.2. Packaging Information	10
10. Reliability Test	11



## MEMS Microphone

### 1. Introduction

The SD3526B MEMS Microphones are integrated with specialized Pre-amplification ASIC to provide high sensitivity, high SNR output from a capacitive audio sensor. It's packaged for surface mounting and high temperature reflow assembly. Data format is a single bit PDM.

### 2. Electrical Parameters

Unless otherwise noted, typical test conditions are  $T_O=25^{\circ}\text{C}$ ,  $V_{DD}=1.8\text{ V}$ . All voltages refer to GND node. The electrical characteristics are measured using a characterization test board.

#### Electrical Characteristics

Parameter	Symbol	Note/Test Condition	Values			Unit
			Min	Typ.	Max	
Power supply voltage	$V_{DD}$		1.62	1.8	3.6	V

#### Standard Mode

Test Condition: Measurement Clock Frequency 2.4 MHz,  $V_{DD} = 1.8\text{ V}$ .

Items	Symbol	Test Condition	Min.	Typ.	Max.	Unit
Directivity		Omni-directional				
Sensitivity	S	94dB SPL @1kHz	-27	-26	-25	dBFS
Current Consumption	$I_{DD}$	Normal mode		650	1000	$\mu\text{A}$
S/N Ratio	SNR	94dB SPL @1kHz A-weighted		65		dB
Total Harmonic Distortion	THD	94dB SPL @1kHz,			0.5	%
Acoustical Overload Point	AOP	10% THD @1kHz		120		dB SPL
Power Supply Rejection	PSR	100mVpp Square wave @217Hz, A-weighted		-90		dBFS



**Low Power Mode**

Test Condition: Measurement Clock Frequency 768 kHz, VDD = 1.8 V

Items	Symbol	Test Condition	Min.	Typ.	Max.	Unit
Directivity		Omni-directional				
Sensitivity	S	94dB SPL @1kHz	-27	-26	-25	dBFS
Current Consumption	I <sub>DD</sub>	Low power mode		350	450	μA
	I <sub>slp</sub>	Fclk OFF		< 1	35	μA
S/N Raito	SNR	94dB SPL @1kHz A-weighted		63		dB
Total Harmonic Distortion	THD	94dB SPL @1kHz			0.5	%
Acoustical Overload Point	AOP	10% THD @1kHz		120		dB SPL
Power Supply Rejection	PSR	100mVpp Square wave @217Hz, A-weighted		-89		dBFS

**Operation Ratings**

Parameter	Symbol	Note/Test Condition	Vales			Unit
			Min	Typ.	Max	
Power supply voltage	V <sub>DD</sub>		1.62		3.6	V
Frequency Range	Sleep Mode		0		350	kHz
	Low Power Mode		512	768	850	kHz
	Standard Mode		1.38		3.3	MHz
Duty Cycle	DC	Note1)	45		55	%
Logic Input High			0.65*V <sub>DD</sub>		V <sub>DD</sub> +0.3	V
Logic Input Low			-0.3		0.35*V <sub>DD</sub>	V
Logic Output High			0.7*V <sub>DD</sub>			V
Logic Output Low					0.3*V <sub>DD</sub>	V
Load Capacitance					200	pF
Startup time					20	ms
Power on					20	ms
Wake-up time				10	20	ms

1) For f<sub>CLK</sub> ≤ 2.7 MHz the duty cycle must be in the range of 45~55 % and for f<sub>CLK</sub> > 2.7 MHz the duty cycle must be in the range of 48~52%



### 3. Timing Characteristics

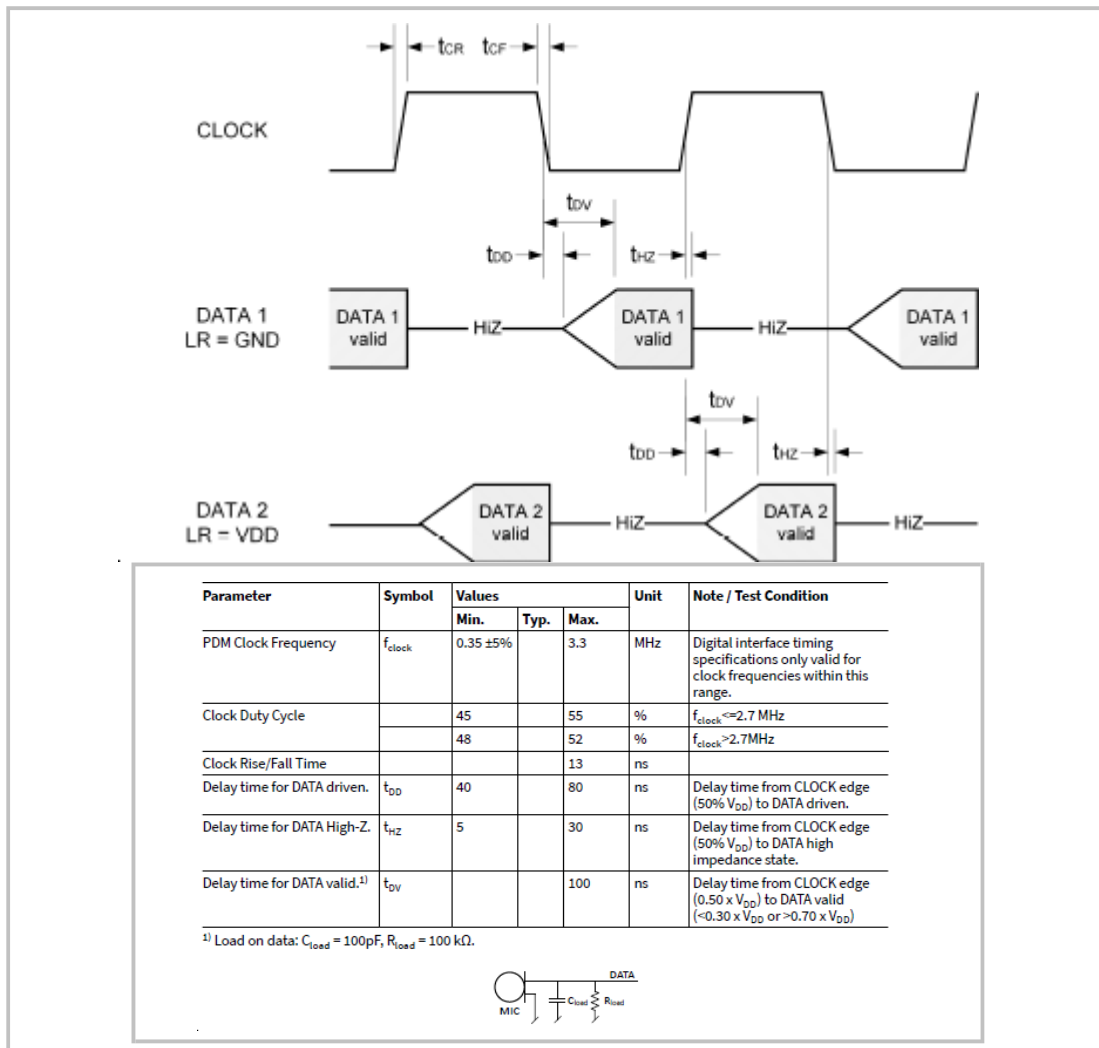

### 4. Frequency Response Curve

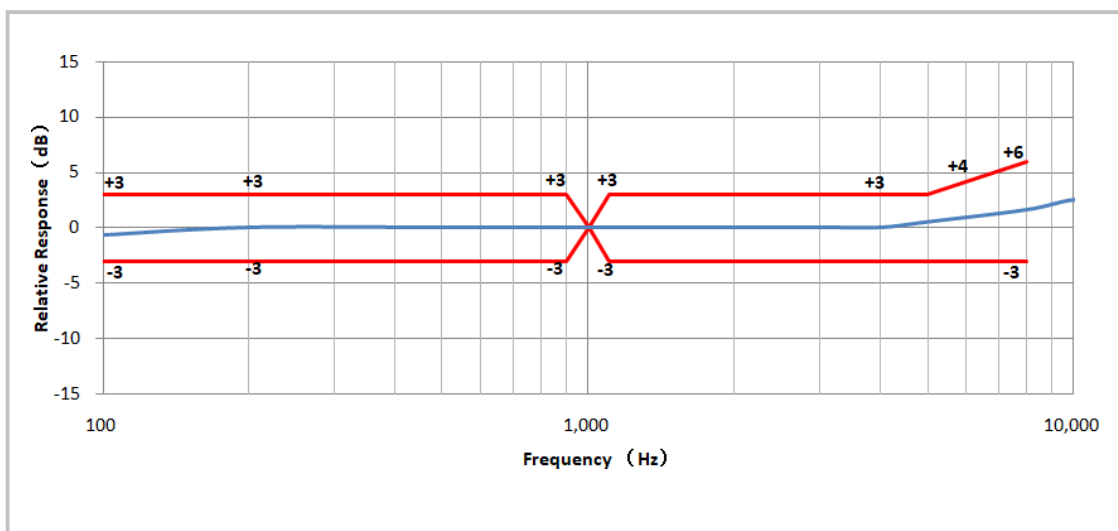

### 5. Test Setup (Sensitivity Test in Anechoic Room)

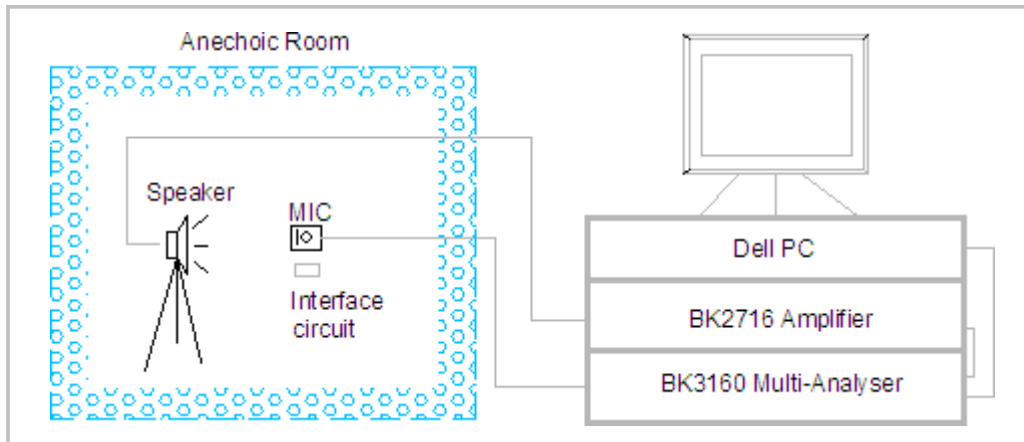

### 6. Measurement Circuit

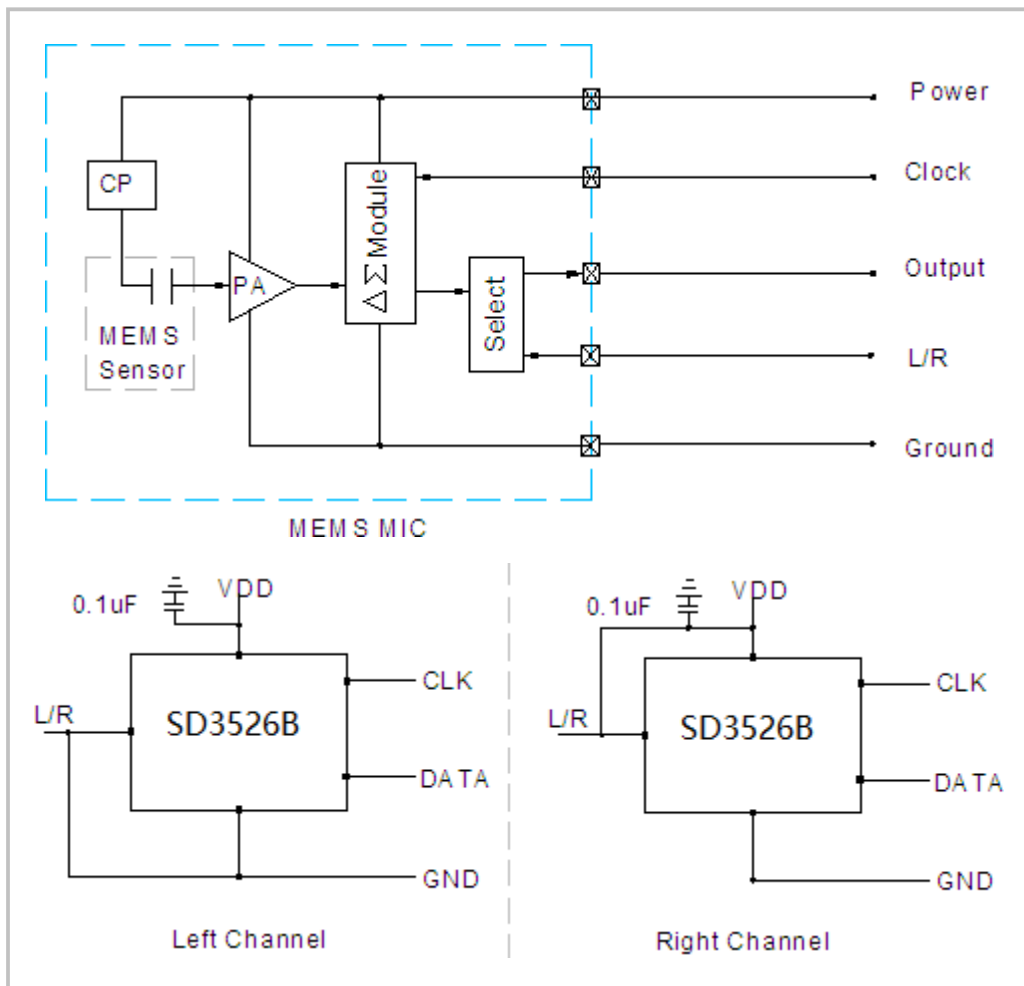

## 7. Mechanical Characteristics

7.1 Weight : Less than 0.3g

7.2 Appearance Drawing(unit: mm)

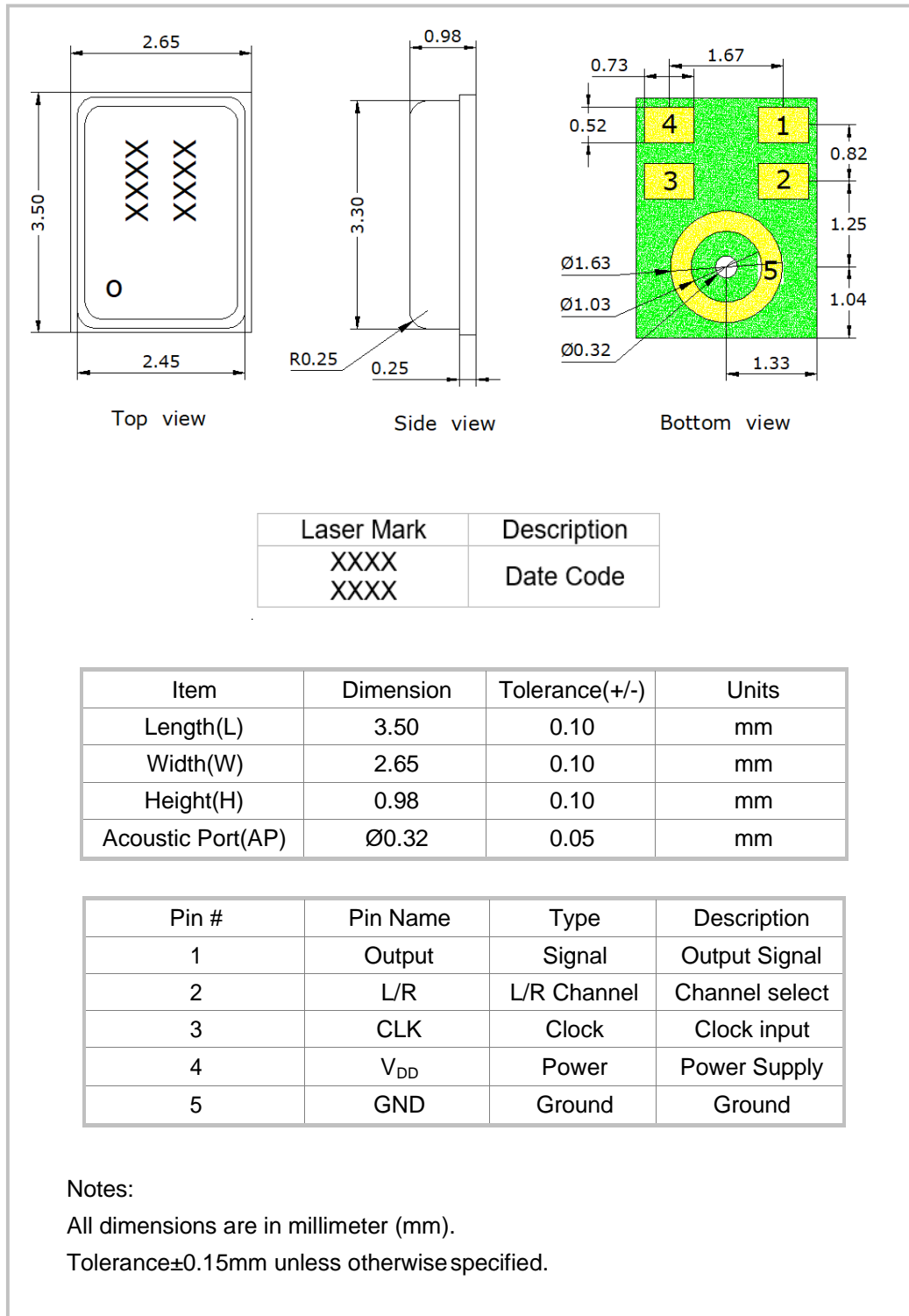

## 8. Application

### 8.1 Pickup Tool Pick Location & PCB Solder Pad Layout

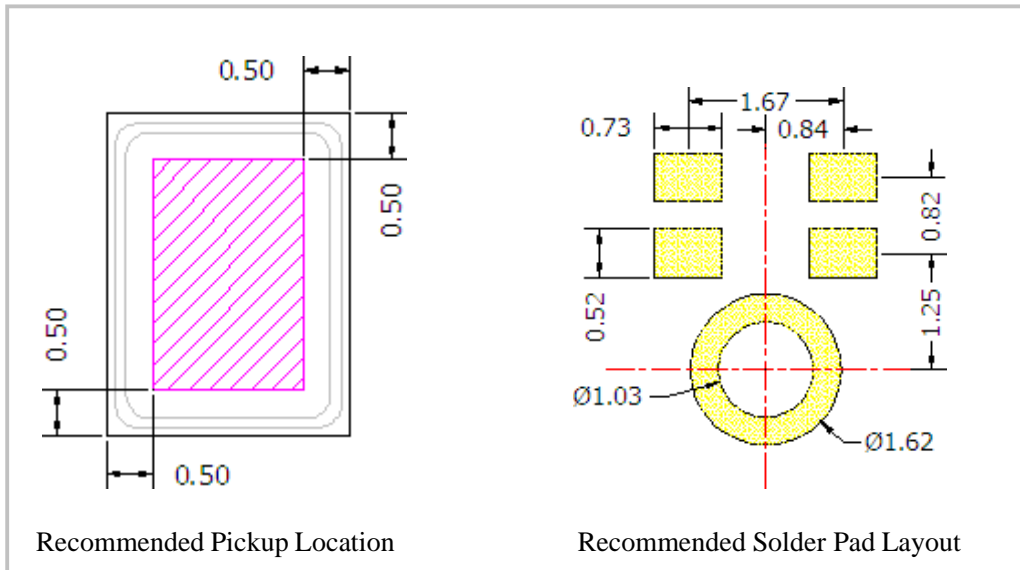

### 8.2 Recommended Reflow Process Condition

Recommend Re-flow Profile, solder reflow  $\leq 260^{\circ}\text{C}$  (for 30s Max of peak temperature).

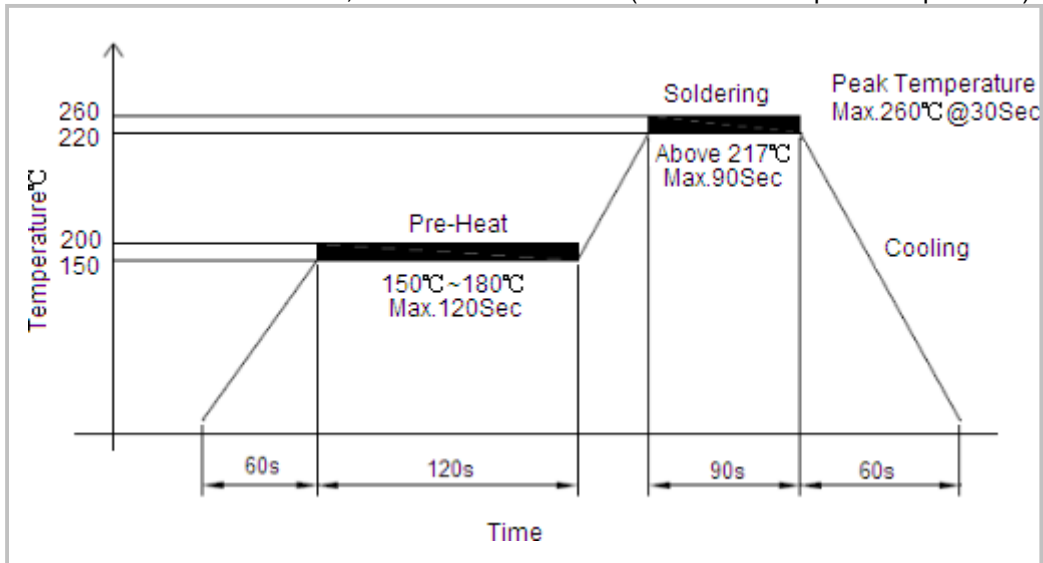

#### Important Notes

In order to minimize device damage:

1. Do not wash or clean the boards after the reflow process.
2. Do not apply the airflow which pressure over 0.3MPa blow into the port hole within a distance of less than 5 cm.
3. Do not exposed to ultrasonic processing or cleaning.
4. Do not pull a vacuum over port hole of the microphone.

### 8.3 Storage Condition



- 8.3.1 Storage temperature range:-40~+70 °C and humidity is less than 75%.
- 8.3.2 Operating temperature range:-40~+100 °C.
- 8.3.3 MSL(moisture sensitivity Level ) is Class 1.

## 9. Packaging

### 9.1 Tape & Reel Specification

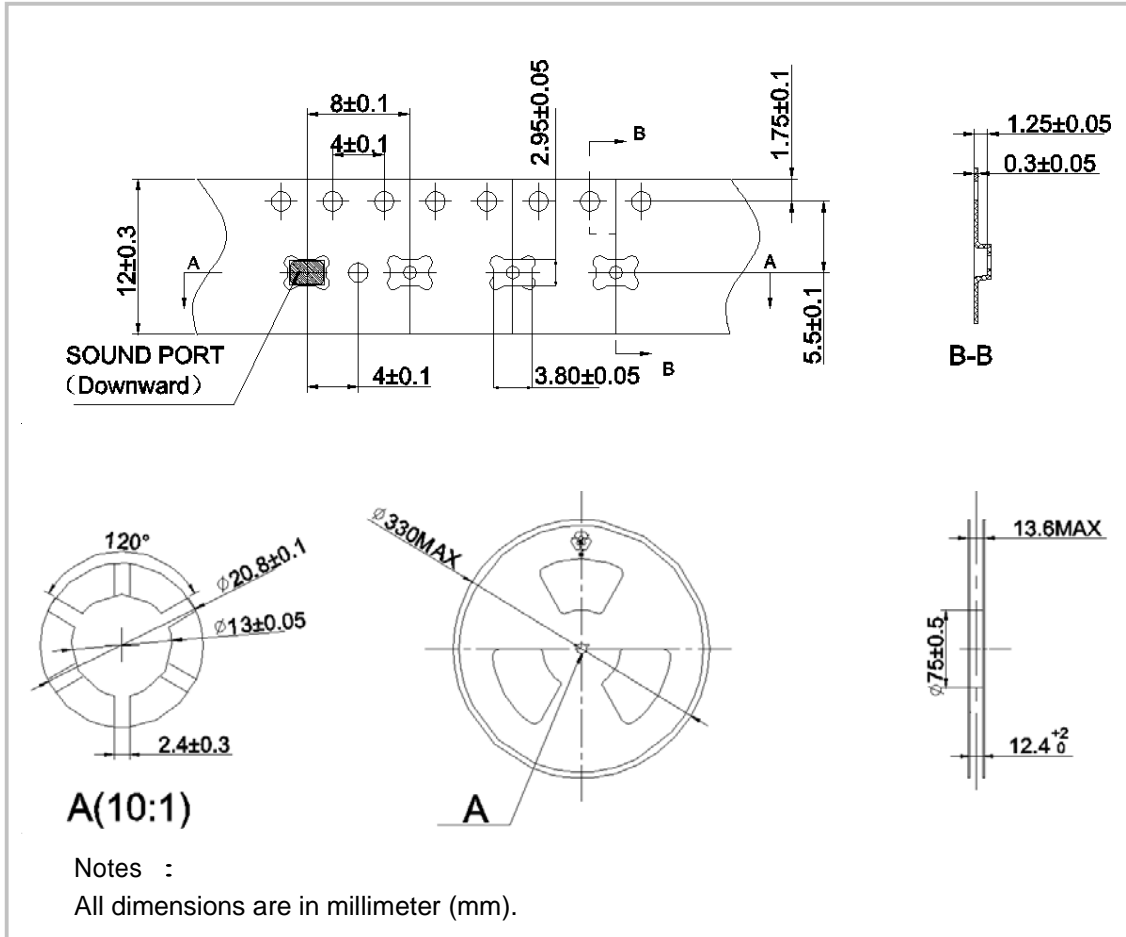



9.2 Packaging Information

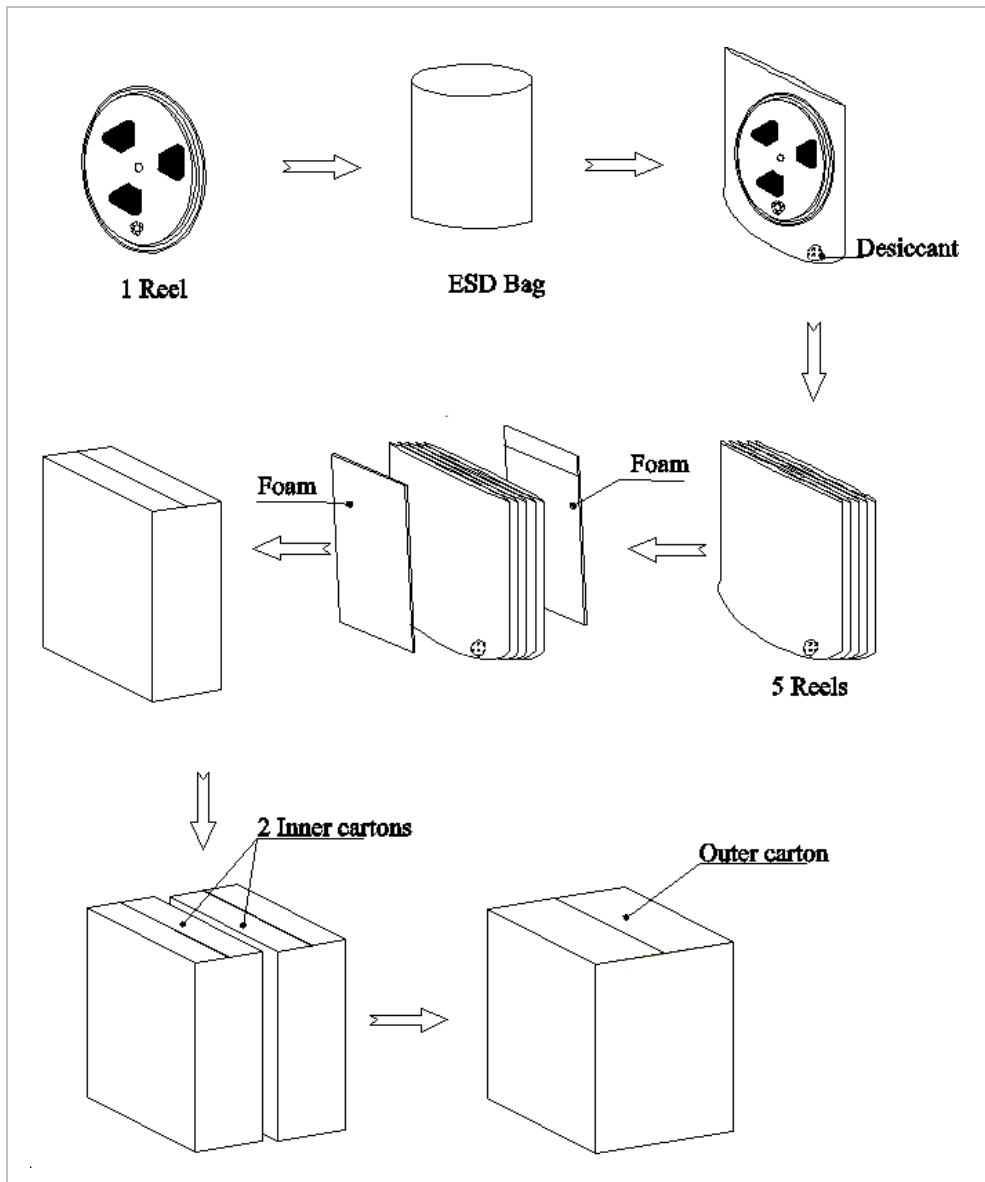

<u>Packaging Quantity</u> :
1 Reel=5000pcs
1 Inner Carton =5Reels=25000pcs
1 Outer Carton=2 Inner Cartons=50000pcs



## 10. Reliability Test

The samples should be placed in the room with  $23\pm 2^{\circ}\text{C}$ ,  $55\pm 10\%\text{R.H.}$  for 2 hours at least before final measurement, unless otherwise specified. After conducting any of the following tests, the sensitivity change of DUT shall be less than  $\pm 3\text{dB}$  from its initial value unless otherwise noted, and shall keep its initial operation and appearance.

NO.	Item	Detail
1	Preconditioning	24 hour bake at $125^{\circ}\text{C}$ , followed by 168 hours at $85^{\circ}\text{C}$ , $85\%\text{RH}$ , followed by 3 passes solder reflow
2	Hi-Temperature Storage Test	$105\pm 3^{\circ}\text{C}$ , 1000h, recover for two hours
3	Hi-Temperature operating Test	$105\pm 3^{\circ}\text{C}$ , under upper limit bias, 1000h, recover for two hours
4	Low-Temperature storage Test	$-40\pm 3^{\circ}\text{C}$ , 1000h, recover for two hours
5	Low-Temperature operating Test	$-40\pm 3^{\circ}\text{C}$ , under upper limit bias, 1000h, recover for two hours
6	High Humidity & High Heat operating Test	$85\pm 3^{\circ}\text{C}$ , $85\%\text{RH}$ , under upper limit bias, 1000h, recover for two hours, there should be no corrosion and deformation inside of microphone after testing
7	High Humidity & High Heat operating Test	$65\pm 3^{\circ}\text{C}$ , $95\%\text{RH}$ , under upper limit bias, 168h, recover for two hours, there should be no corrosion and deformation inside of microphone after testing
8	Thermal Shocking Test	Double-Case Method, $-40^{\circ}\text{C}$ for 15mins $\rightarrow$ $125^{\circ}\text{C}$ for 15 mins, 100 cycles, recover for two hours
9	Vibration Test	Each 12mins for X, Y and Z axes, Frequency: 20~2000Hz, Peak Acceleration 20g, recover for two hours
10	Drop Test	Height: 1.5m Fixture Weight: 150g (Sound Hole Diameter in the fixture is $\geq 0.8\text{mm}$ ) Reference Surface: slippery marble floor Duration: 4 corners*4 times, 6 faces*4 times The sensitivity change should be less than 1dB after testing



11	Tumbling Test	<p>Height:1.0m</p> <p>Fixture Weight:150g</p> <p>(Sound Hole Diameter in the fixture is <math>\geq 0.8\text{mm}</math>) Duration: 300 times</p> <p>Recommended Time: 10-11times/Min</p> <p>The sensitivity change should be less than 1dB after testing</p>
12	ESD Test 1	<p>a. HBM Discharge Position: I/O pins</p> <p>Charge Voltage: <math>\pm 3000\text{V}</math></p> <p>Discharge Network: 100pF &amp; 1500<math>\Omega</math></p> <p>b. CDM Discharge Position: I/O pins</p> <p>Charge Voltage: <math>\pm 250\text{V}</math></p>
13	ESD Test 2	<p>The tests are performed acc. to IEC61000-4-2 level 3:</p> <p>a. Contact Discharge</p> <p>Discharge Position: Output of Microphone Charge</p> <p>Voltage:<math>\pm 6000\text{VDC}</math></p> <p>Discharge Network:150pF &amp; 330<math>\Omega</math></p> <p>b. Air Discharge</p> <p>Discharge Position: Sound Hole</p> <p>Charge Voltage:<math>\pm 8000\text{VDC}</math></p> <p>Discharge Network:150pF &amp; 330<math>\Omega</math></p>
14	Structure Shock Test	<p>10000g, Duration: 0.1ms, each 3 shocks for X/Y/Z 3 axes, The sensitivity change should be less than 1dB after testing</p>
15	Reflow	<p>3 reflow cycles with peak temperature of <math>+260^{\circ}\text{C}</math> according to reflow profile</p>

